

GAR3-16 Full Extension Mini Slide

Max load 4kg

Features

- Full extension (3 members)
- Only 16 mm in height, suitable for various applications
- Light weight outer and inner members made of aluminium alloy extruded material

Notes

- Install stopper separately to protect rails and retainers from strong shock

Recommended Screws

- M2.5 low head screw



No.	Part Name	Material	Finish
①	Outer Member	Aluminium Alloy	Anodised Silver
②	Inner Member		
③	Retainer	Steel (SECC)	(Zinc Chromate Steel)
④	Balls	Steel (SWCH)	-

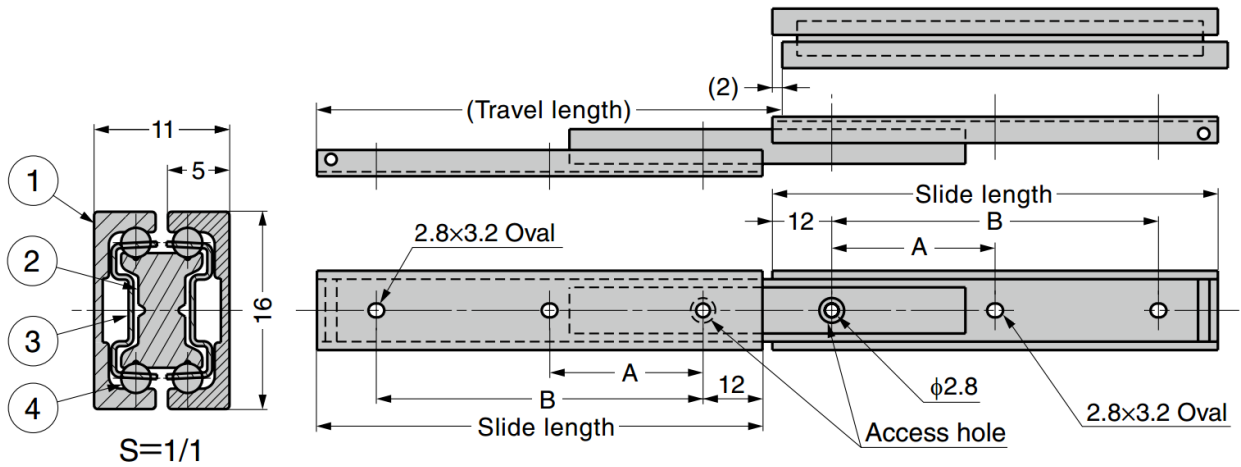

Sold in pieces

Part No.	Slide Length	Travel Length	A	B	Load Capacity (per pair)	
GAR3-16-80	80	77	-	56	20 N	2 kg
GAR3-16-100	100	117	38	76	29 N	3 kg
GAR3-16-150	150	151	63	126	39 N	4 kg